

SPREAD AXLE LOWBOY SERIES



65SA MODULAR TRAILER / E2NITRO™
Optional Decks: Level, Raised Center, Beam, & Perimeter Frame

65SA MODULAR TRAILER



70" Gooseneck Extension and convertible Jeep Dolly with removable axles, sliding 5th wheel, and multiple kingpin settings.



E2Nitro™ distributes weight to rear axle group via hydraulic / nitrogen accumulator system; dampening axle movement and controlling load transfer.



E2Nitro™ is standard with gas engine power pack to drive loading cylinders via controls shown.

65SA MODULAR TRAILER/E2NITRO™

Dealer:

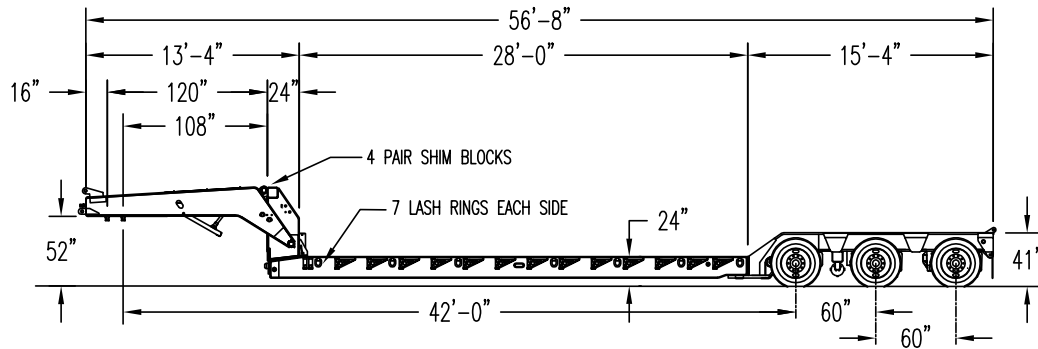

- Non-Ground Bearing Gooseneck Design
- 120 in. Swing Radius with Connections for up to 70 in. Gooseneck Extension
- Hydraulic Support Cylinder (Standard)
- Front Folding / Fixed Ramps (Optional)
- 28 ft. 0 in. Deck Length
- 12 in. Swinging / Removable Outriggers
- 8 ft. 6 in. Wide Deck
- 24 in. Loaded Deck Height / 6 in. Loaded Road Clearance
- 1/4 in. Plate Bucket Well, Last 6 ft. of Deck
- High Strength 100,000 psi Minimum Yield Steel
- 2 in. Apitong Flooring
- Two Sections Chain Storage
- Axles: 25,000 lb. Capacity
- **RIDEWELL** Suspension: Air Ride with Automatic and Talbert +3 in./-3 in. Manual Control
- Manual Raising / Lowering Valve
- Tires: 275/70R22.5 (H)
- Wheels: Steel Disc, Hub Piloted with Outboard Brake Drums
- Bolsters and Half Bolster on Rear Bridge
- 41 in. Mainbeam / 37 in. Bolster Height
- Boom Well in Rear Bridge
- Spring Parking Brake on Axle Two
- Up to 5 Axles Close Couple and 3+2 E2Nitro™ Spread Capable
- Removable Axles (RA / Modular)
- Reinforced for Various Decks / Inserts
- 12 Volt LED Sealed Light System
- 130,000 lb. Capacity in 14' (5) Axle
- Close Coupled or 3+2 Spread Axle
- 140,000 lb. Capacity in 15' (4) Axle Close Couple
- Estimated 3-Axle Base Trailer Weight: 31,750 lbs.
- **Valspar** R-Cure 800 Red or Black Paint

Various Options Available Upon Request. Specifications Subject To Change Without Notice.

3+3+2 CONFIGURATION

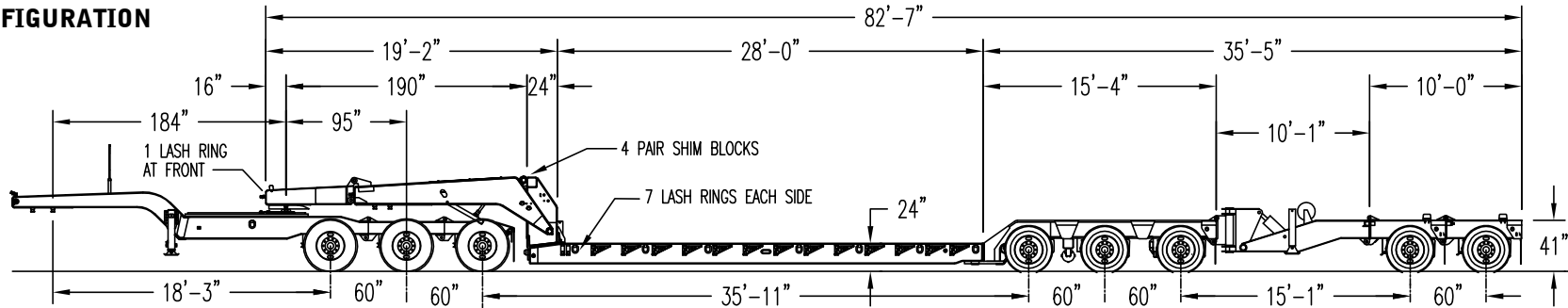

2+3+2 CONFIGURATION

