

# SPREAD AXLE LOWBOY SERIES



**55SA-HX**



**55SA-HX**



Industry-leading standard 114"/90" dual kingpin setting for versatility and greater load transfer capability.



Rugged, heavy-duty deck courtesy of auxiliary cross-members and top flange reinforcement.



Allows users to operate as a 3+1 spread-axle with the E1Nitro™. Can also function as four axle close coupled.

# 55SA-HX

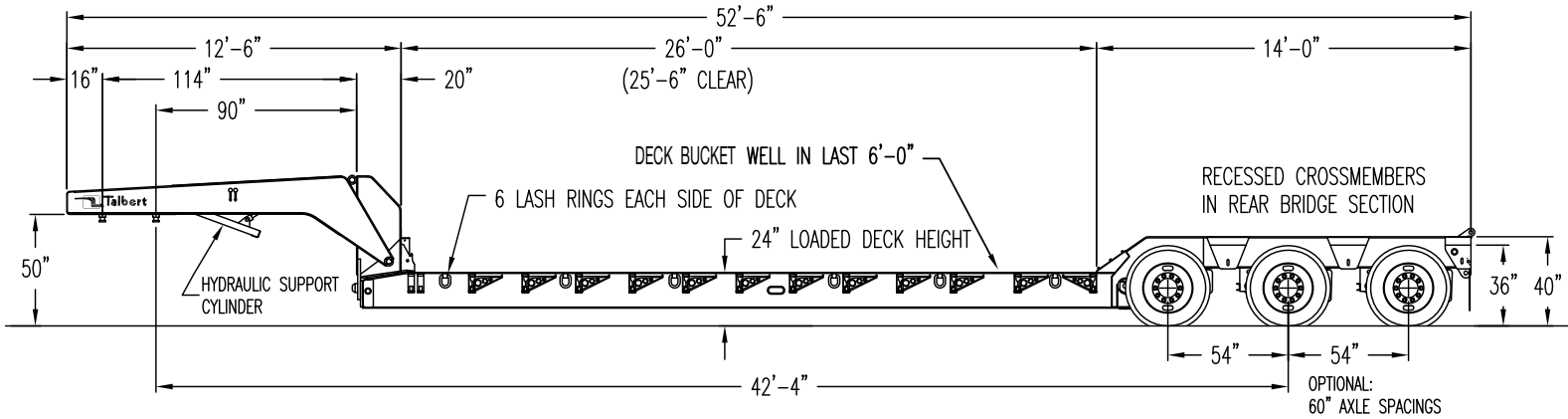

- Non-Ground Bearing Gooseneck Design
- 114/90 in. Dual Swing Radius
- Hydraulic Support Cylinder (Standard)
- Front Folding Ramps (Optional)
- 26 ft. 0 in. Deck Length
- 12 in. Swinging / Removable Outriggers
- 8 ft. 6 in. Wide Deck
- 24 in. Loaded Deck Height / 8 in. Loaded Road Clearance
- Auxiliary Crossmembers (HX Standard)
- Upper Flange Reinforcement (Optional)
- 1/4 in. Plate Bucket Well in Last 6 ft. of Deck
- High Strength 100,000 psi Minimum Yield Steel
- Axles: 25,000 lb. Capacity
- Air Lift 3rd Axle (Optional)
- Outrigger Boards (Optional)
- **RIDEWELL** Suspension: Air Ride with Automatic and Talbert +3 in. / -3 in. Manual Control
- Manual Exhaust Valve (Optional)
- Tires: 255/70R22.5 (H)
- Wheels: Steel Disc, Hub Piloted with Outboard Brake Drums
- Bolsters and Half Bolster on Rear Bridge
- 40 in. Mainbeam / 36 in. Bolster Height
- Boom Well in Rear Bridge
- Spring Parking Brake on Axle Two
- 4th Axle Capable with or without Axle Extension
- 12 Volt LED Sealed Light System
- Strobes and Battery Backup (Optional)
- 110,000 lb. Capacity in 1/2 Deck Length  
110,000 lb. in 16ft. when 3+1
- Estimated Weight: 21,660 lbs.
- **Valspar R-Cure 800 Red or Black Paint**

Various Options Available Upon Request. Specifications Subject To Change Without Notice.



Pictured with optional rear bridge fenders.

Dealer:



Talbert Manufacturing Inc. \ 1628 W. State Road 114 \ Rensselaer IN 47978 \ 800-348-5232 \ Fax: 219-866-7060

sales@talbertmfg.com \ www.talbertmfg.com

0315 PUB 234B